



DATASHEET

QUICK CHANGER
DUAL QUICK CHANGER
QUICK CHANGER FOR I/O
QUICK CHANGER TOOL SIDE

V1.1

Datasheet

If not specified, the data represent the combination of the different Quick Changer types/sides.

Technical data	Min	Typical	Max	Units
Permissible force*	-	-	400*	[N]
Permissible torque*	-	-	50*	[Nm]
Rated payload*	-	-	20* 44	[kg] [lbs]
Repeatability	-	-	±0.02	[mm]
IP Classification	64			
Operating life (Tool change)	-	5.000	-	[cycles]
Operating life (Robot operation)	10	-	-	[M cycles]

* See load capacity graph below.

	Quick Changer	Quick Changer for I/O	Dual Quick Changer	Quick Changer - Tool Side	Units
Weight	0.06	0.093	0.41	0.14	[kg]
	0.13	0.21	0.9	0.31	[lb]
Dimensions	See Mechanical dimension section				

Load capacity

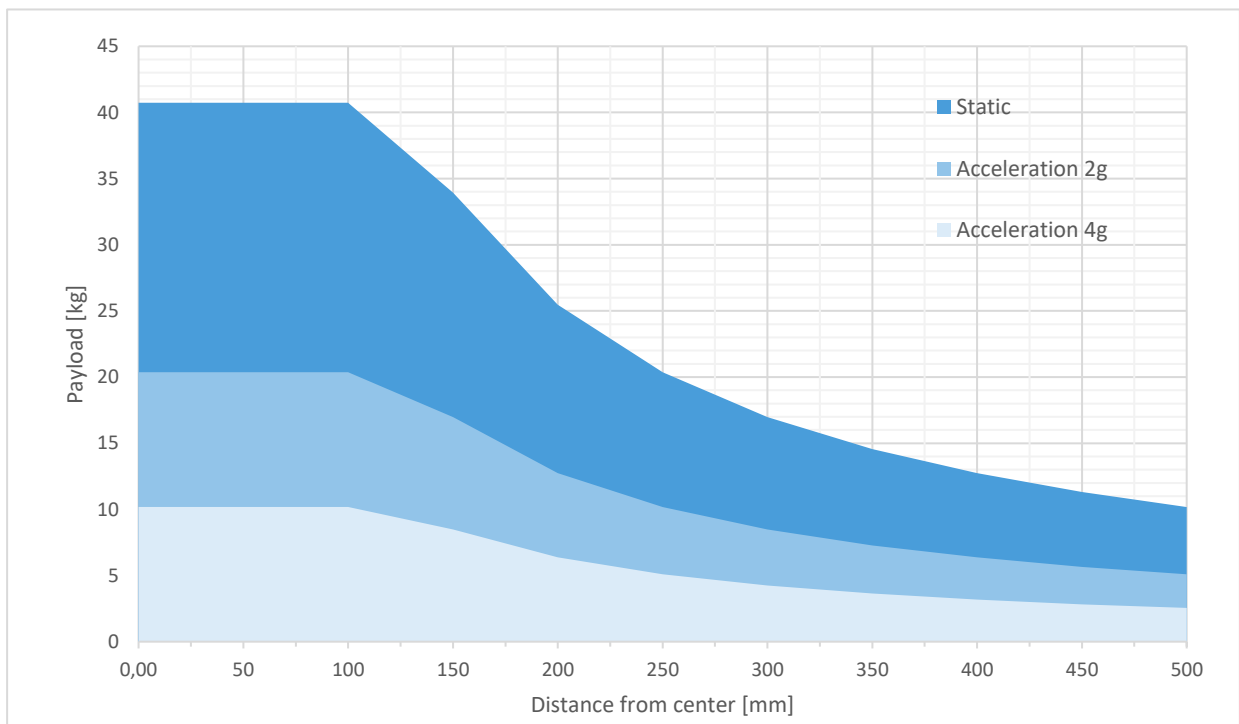

**Quick Changer -
Robot side**

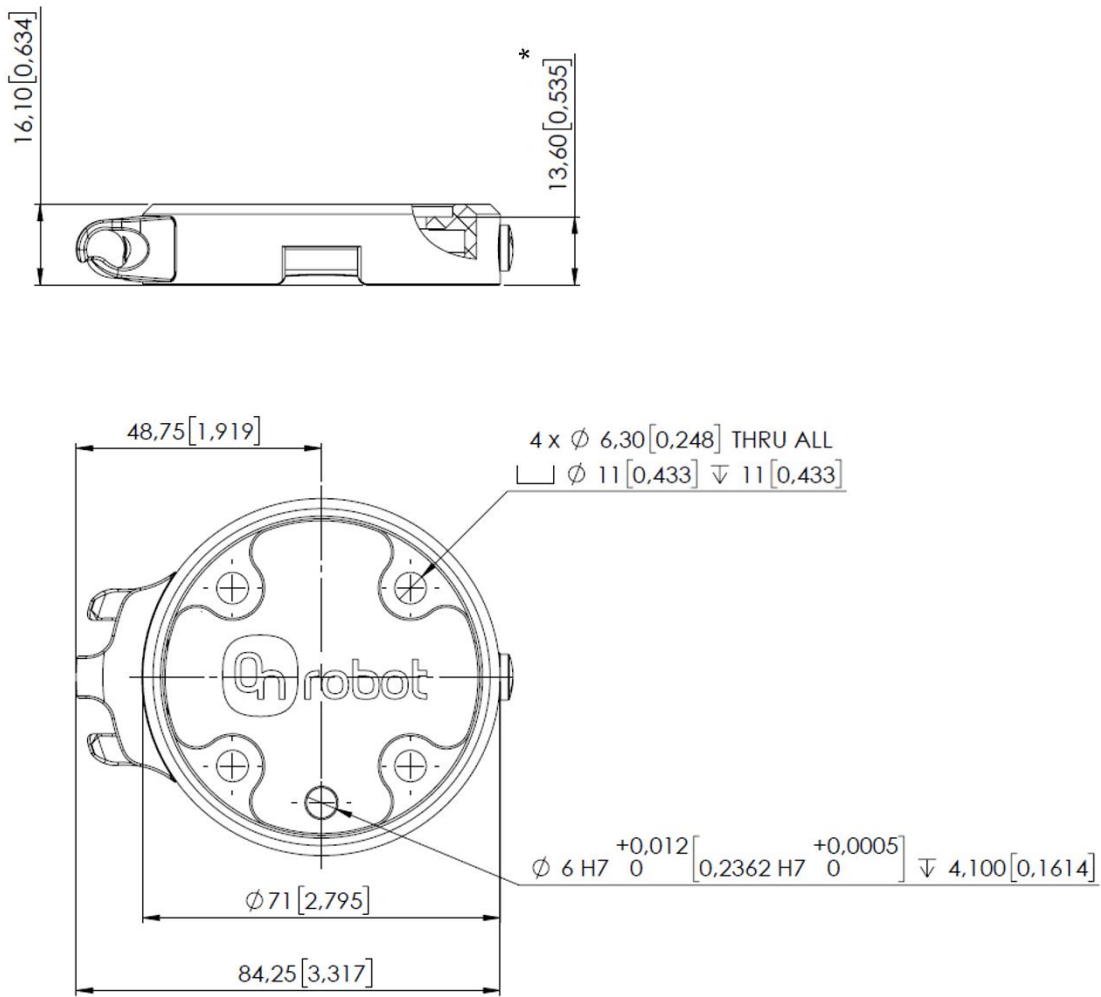

* Distance from Robot flange interface to OnRobot tool.

All dimensions are in mm and [inches].



NOTE:

The cable holder (on the left side) is only required with the long (5 meter) cable.

Dual Quick Changer

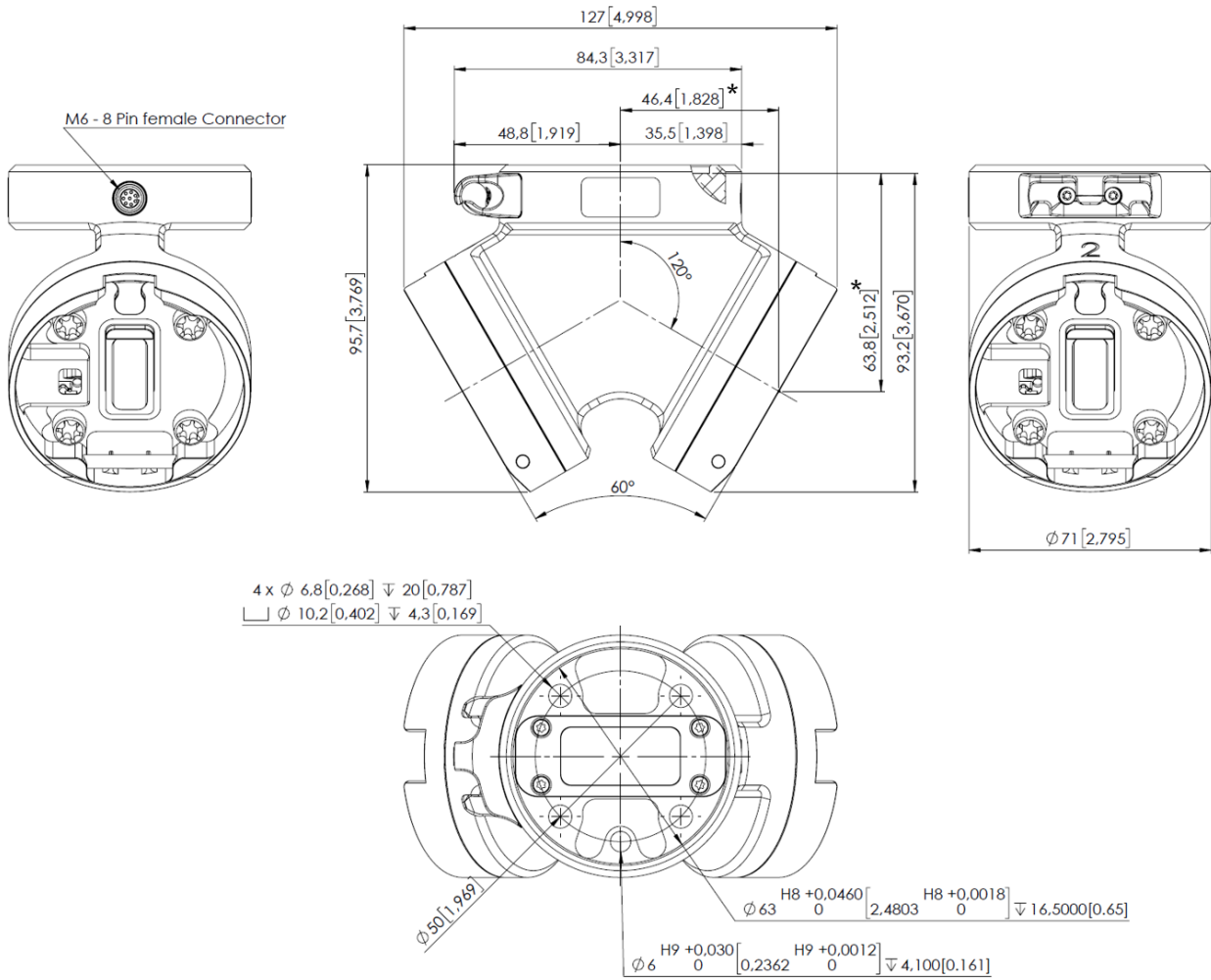

* Distance from Robot flange interface to OnRobot tool

All dimensions are in mm and [inches].

Quick Changer for
I/O - Robot side

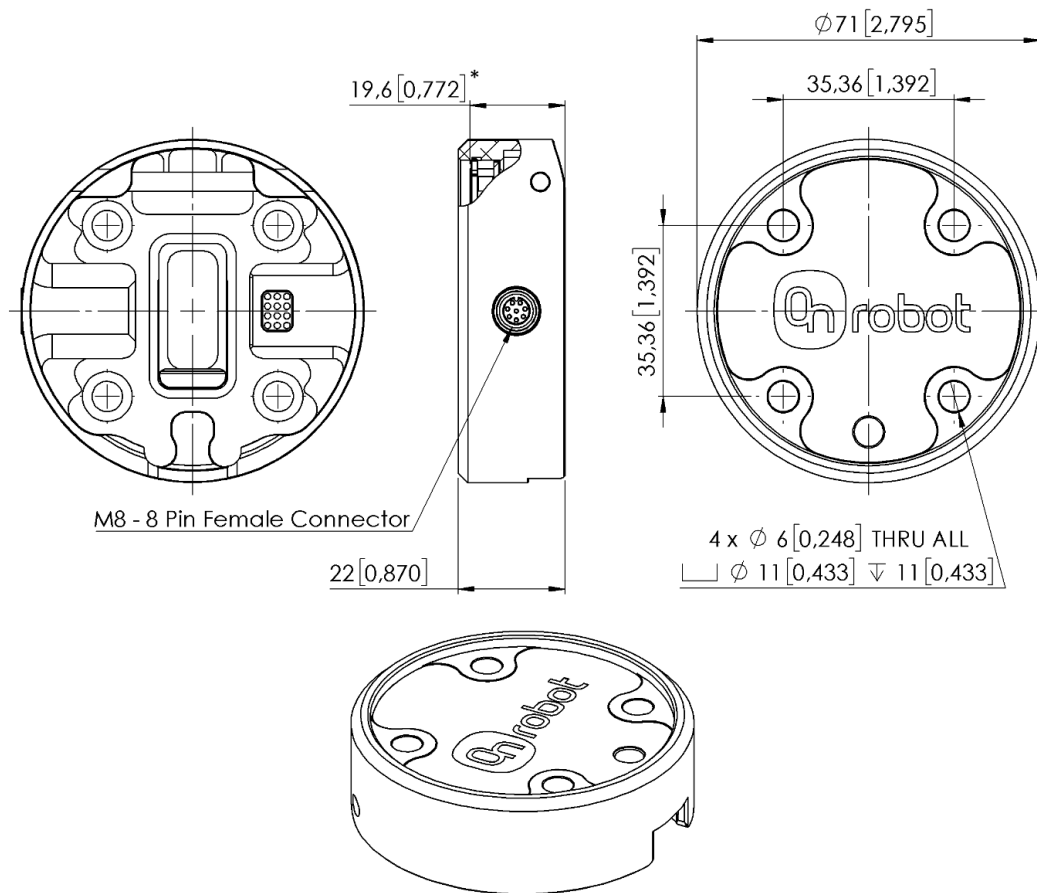

* Distance from Robot flange interface to OnRobot tool

All dimensions are in mm and [inches].

Quick Changer -
Tool side

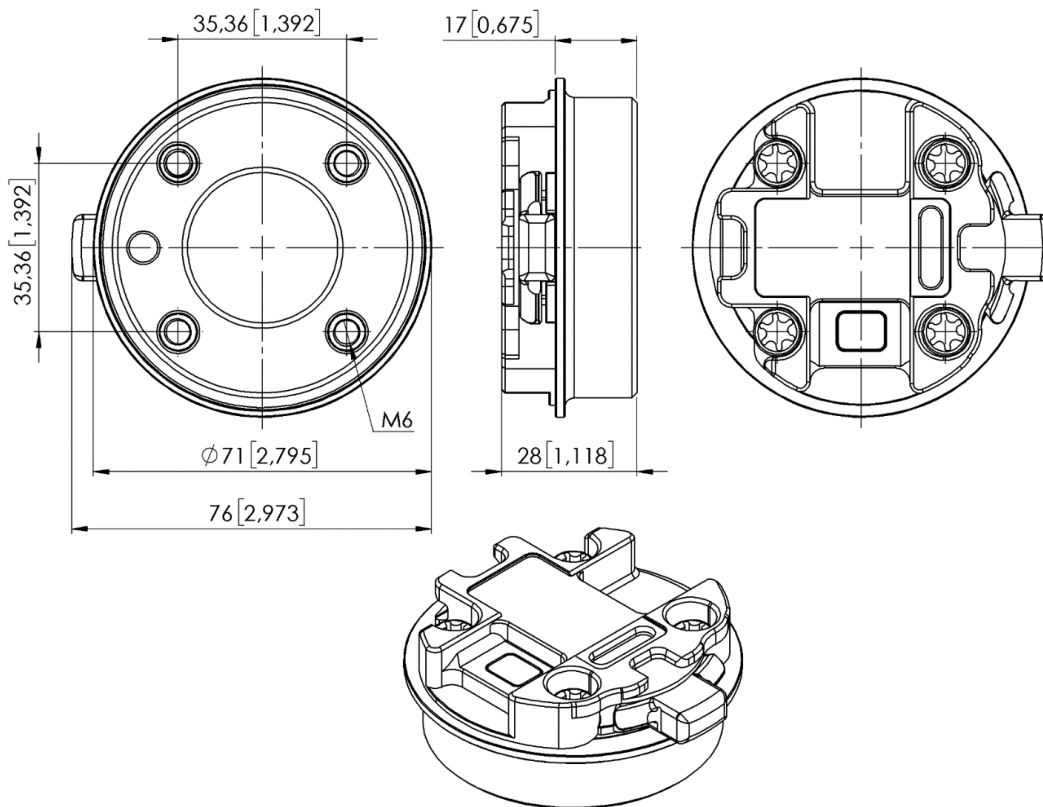

All dimensions are in mm and [inches].